

STANDARD STEAM TRIM

- Operating & Limit Pressure Control.
- Low Fire Hold Aquastat.
- Modulating Pressure Control (When Applicable).
- Water Column with Gauge Glass Float Type Combination Low Water Cut-Off & Pump Control (Optional).
- Probe Type Auxiliary Low Water Cut-Off Float or Probe with Manual Reset (Optional).
- Water Column Drain Valve.
- Safety Relief Valve(s) Per ASME Code.
- Stack Thermometer.
- Steam Pressure Gauge.

STANDARD WATER TRIM

- Operating & Limit Temperature Control.
- Modulating Temperature Control (When Applicable).
- Low Water Cut-Off Control Float or Probe with Manual Reset.
- Combination Pressure, Temperature Gauge.
- Safety Relief Valve(s) Per ASME Code.
- Stack thermometer.

PACKAGED BOILERS

Industrial Steam Boiler Series ISB3, Scotch Marine, Horizontal Firetube 3-Pass packaged, combustion systems are manufactured for use in low-pressure steam (15 PSIG) or hot-water (30 to 160 PSIG), maximum 250 °F applications, providing for efficient operation and low-cost maintenance. Complete packaged units piped wired and ready for years of reliable low-cost maintenance efficient operation. ASME & UL approved with many brands different fuels with automatic burners.

FIELD ERECTED BOILERS

Industrial Steam Boiler Series ISB3 Scotch Marine field erected boilers fill the long-standing need for a quality steel boiler that can be moved into an existing boiler room through available door openings and/or windows. Series ISB3 Three Pass boilers are the industry standard for an Advanced Scotch Marine, full water back design and are built with the same high-quality components, workmanship, generous, proportions and engineering excellence that are synonymous with all our factory-built packaged boilers.



- **THREE PASS WATER BACK DESIGN**
- **LOW PRESSURE STEAM UP TO 15 PSI**
- **HOT WATER UP TO 160 PSI**
- **ASME SECTION IV LOW PRESSURE HEATING BOILERS**
- **CAPACITY FROM 50 TO 600 BHP (700 BHP UP TO 1000 BHP CUSTOM DESIGN)**
- **LARGE FURNACE VOLUME**
- **PACKAGED WITH GAS, OIL OR COMBINATION GAS/OIL LONOX BURNERS**
- **COMPLIES WITH ASME, UL, CSD-1 & ASHRAE STANDARDS**
- **BEST BOILER WARRANTIES IN THE INDUSTRY**

RATINGS

BOILER SIZE		HP	50	60	70	80	90	100	125	150	175	200	250	300	350	400	450	500	600
GROSS OUTPUT	STEAM	LBS/HR	1,725	2,070	2,415	2,760	3,105	3,450	4,313	5,175	6,038	6,900	8,625	10,350	12,075	13,800	15,525	17,250	20,700
	STEAM/WATER	MBH	1,674	2,009	2,343	2,678	3,013	3,348	4,184	5,021	5,858	6,695	8,369	10,043	11,716	13,390	15,064	16,738	20,085
NET RATINGS	STEAM	MBH	1,299	1,559	1,819	2,079	2,339	2,599	3,249	3,898	4,548	5,198	6,497	7,797	9,096	10,396	11,695	12,995	15,594
	WATER	MBH	1,455	1,747	2,038	2,329	2,620	2,911	3,639	4,366	5,094	5,822	7,277	8,733	10,188	11,643	13,099	14,554	17,465
	STEAM	SQ. FT	5,415	6,497	7,580	8,663	9,746	10,829	13,536	16,244	18,951	21,658	27,073	32,487	37,902	43,317	48,731	54,146	64,975
FIRING RATE	NATURAL GAS	CFH	2,092	2,511	2,929	3,348	3,766	4,184	5,230	6,277	7,323	8,369	10,461	12,553	14,645	16,738	18,830	20,922	25,106
	#2 OIL	GPH	15	17	20	23	26	29	36	44	51	58	73	87	102	117	131	146	175
	#6 OIL	GPH	14	16	19	22	24	27	34	41	48	54	68	82	95	109	122	136	163
FIRESIDE HEATING SURFACE	SQ. FT	250	300	350	400	450	500	625	750	875	1,000	1,250	1,500	1,750	2,000	2,250	2,500	3,000	
FURNACE VOLUME	CU. FT	33	38	44	49	53	65	77	89	95	103	119	134	204	227	249	304	349	
HEAT RELEASE RATE	MBH/FT ²	63	65	66	69	71	64	68	70	77	81	88	93	72	74	76	69	72	
WATER CONTENTS	GALS.	289	363	383	450	518	473	601	722	873	1,008	1,290	1,572	1,762	2,037	2,312	2,501	3,031	
APPROX. SHIPPING WEIGHT	LBS	5,500	5,900	6,800	7,500	8,000	9,300	10,700	12,000	13,200	14,100	16,400	18,800	23,500	26,000	28,500	32,500	36,100	
APPROX. OPERATING WEIGHT	LBS	7,917	8,931	9,994	11,256	12,328	13,246	15,718	18,027	20,489	22,520	27,175	31,930	38,216	43,008	47,801	53,384	61,413	
APPROX. FLOODED WEIGHT	LBS	8,943	10,169	11,797	13,317	14,647	16,172	19,321	22,370	24,827	27,402	33,190	39,078	49,516	55,855	62,195	63,314	73,199	

NOTE: OVERALL EFFICIENCY CAN GO AS HIGH AS 86%.

DIMENSIONS

BOILER SIZE		50	60	70	80	90	100	125	150	175	200	250	300	350	400	450	500	600
A	INSIDE DIAMETER-SHELL	55	55	63	63	63	72	72	72	84	84	84	84	96	96	96	108	108
B	INSIDE DIAMETER-FURNACE	27	27	30	30	30	37-1/4	37-1/4	37-1/4	37-1/4	37-1/4	37-1/4	37-1/4	47	47	47	57	57
C	BOILER WIDTH-OVERALL	59-7/8	59-7/8	67-7/8	67-7/8	67-7/8	76-7/8	76-7/8	76-7/8	88-7/8	88-7/8	88-7/8	88-7/8	100-7/8	100-7/8	100-7/8	112-7/8	112-7/8
D	BOILER HEIGHT-OVERALL	72-3/4	72-3/4	81-3/4	81-3/4	81-3/4	90-3/4	90-3/4	90-3/4	102-3/4	102-3/4	102-3/4	102-3/4	114-3/4	114-3/4	114-3/4	126-3/4	126-3/4
E	BOILER LENGTH-OVERALL	107-3/8	122-3/8	113-7/8	124-7/8	135-7/8	115-7/8	134-7/8	153-7/8	134	146	171	196	210	232	254	217	247
F	LENGTH OF SHELL	76	91	80	91	102	82	101	120	99	111	136	161	164	186	208	164	194
G	LENGTH OF FURNACE	58	73	62	73	84	64	83	102	68	80	105	130	133	155	177	127-1/2	157-1/2
H	NORMAL WATER LINE	58	58	63-1/4	63-1/4	63-1/4	73	73	73	80	80	80	80	88	88	88	104	104
I	C.L. OF FURNACE	28-7/8	28-7/8	31	31	31	34-5/8	34-5/8	34-5/8	34-15/16	34-15/16	34-15/16	34-15/16	41-11/16	41-11/16	41-11/16	47	47
J	LENGTH-REVERSING CHAMBER	18-3/4	18-3/4	18-3/4	18-3/4	18-3/4	18-3/4	18-3/4	18-3/4	32	32	32	32	32	32	32	38	38
K	HEIGHT-FRONT SMOKE BOX	56-7/8	56-7/8	62-1/16	62-1/16	62-1/16	72-1/4	72-1/4	72-1/4	78-15/16	78-15/16	78-15/16	78-15/16	86-13/16	86-13/16	86-13/16	103-1/8	103-1/8
L	RETURN LOCATION	35	35	35	35	35	35	48	48	48	48	48	48	55	55	55	60	60
M	SUPPLY LOCATION	29	29	29	29	29	29	33	33	37	37	37	37	67	67	67	64	64
N	STEAM SUPPLY SIZE (NPS)	6	6	6	6	6	8	8	8	8	8	10	10	10	10	10	12	12
O	WATER SUPPLY SIZE (NPS)	3	3	4	4	4	4	4	6	6	6	6	6	6	8	8	8	8
P	STEAM RETURN SIZE (NPS)	4	4	4	4	4	4	4	4	4	4	4	4	6	6	6	6	6
Q	WATER RETURN SIZE (NPS)	3	3	4	4	4	4	4	6	6	6	6	6	6	8	8	8	8
R	FRONT DOOR SWING	28	28	32	32	32	37	37	37	43	43	43	43	49	49	49	55	55
S	REAR DOOR SWING	16	16	21	21	21	26	26	26	33	33	33	33	34	34	34	44	44
T	LENGTH OF SADDLE	40	40	48	48	48	56	56	56	62	62	62	62	76	76	76	94	94
U	WIDTH OF SADDLE	7	7	8	8	8	8	8	8	8	8	8	8	10	10	10	12	12
V	VENT DIAMETER	12-3/4	12-3/4	18	18	18	18	18	18	20	20	20	20	26	26	26	32	32
W	TUBE PULL	76	91	80	91	102	82	101	120	99	111	136	161	164	186	208	164	194

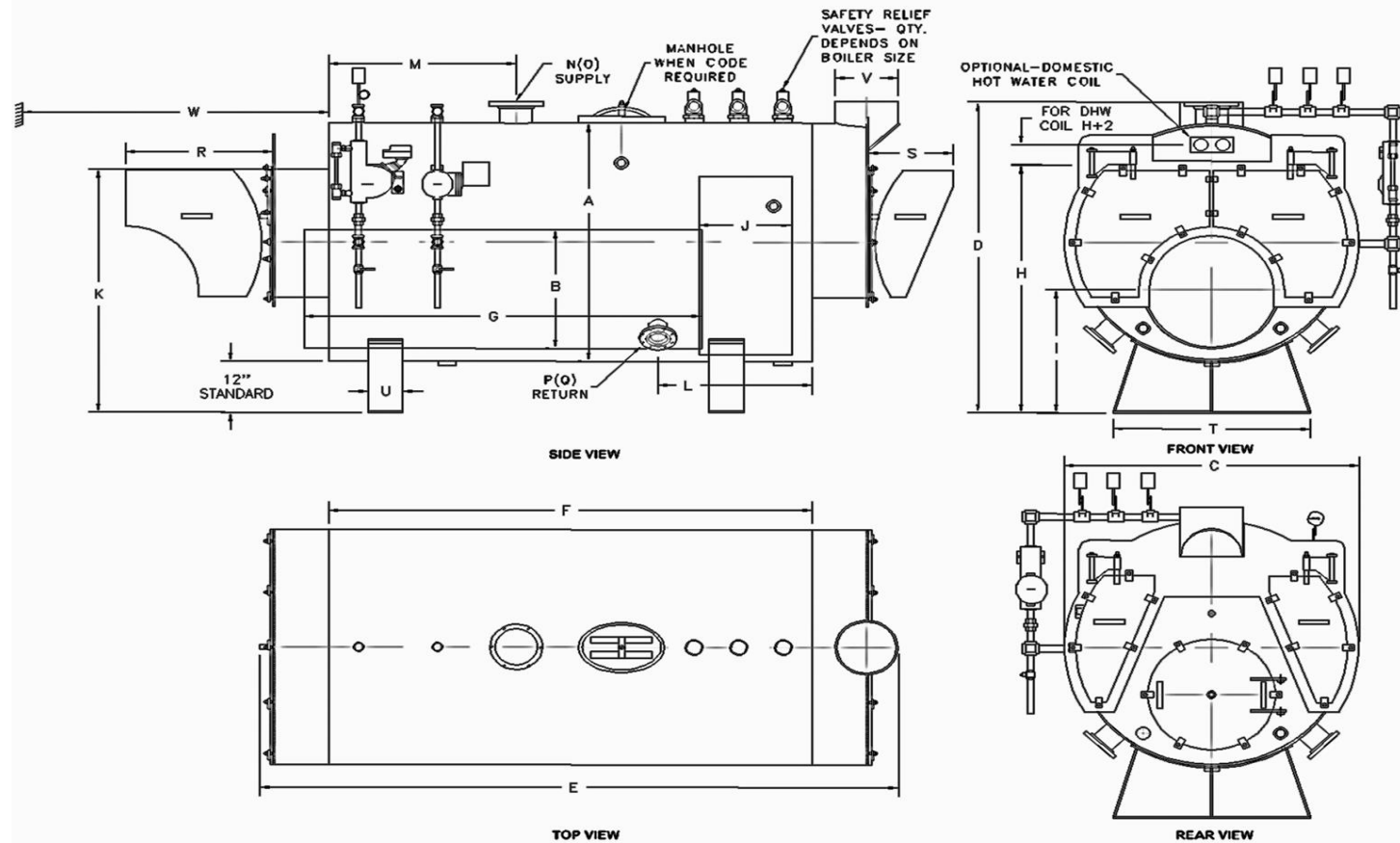

OPTIONAL TANKLESS DOMESTIC HOT WATER COIL

FAMILIES OR BATH	8	12	16	24	34	42	50	60	70	90	100	120	130	140	150	160	180	200	225	250	300	350	400
RATING GPH 40F TO 140F WITH B.W AT 180	400	480	560	640	720	840	960	1080	1200	1400	1600	1800	2000	2200	2400	2600	2880	3160	3440	3720	4000	4400	4800

NOTES: -

- ALL DIMENSIONS ARE IN INCHES CERTIFIED DRAWINGS ARE AVAILABLE UPON REQUEST.
- DIMENSIONS SUBJECT TO CHANGE WITHOUT NOTICE.
- DESIGNED AND BUILT IN STRICT ACCORDANCE WITH ASME.
- BOILERS ARE AVAILABLE AS COMPLETE PACKAGES OR FIELD ERECTED.
- TRIM PACKAGE SUBJECT TO CHANGE WITHOUT NOTICE.

70 LAMBERT AVENUE
 COPIAGUE, NY 11726 USA
 PH: (718)665-0888 FAX: (718)402-4336

WWW.ISBNYC.COM

INFO@ISBNYC.COM